

MINIJET 280

LENGTH O.A.	2.79m (±1%)
BEAM O.A.	1.54m (±1.5%)
DRAFT (LOAD DEPENDANT)	0.24m / 0.35m
ENGINE	Rotax ACE 60 ECT
POWER	60hp ≅ 44.13kW
DRY WEIGHT	225kg
SEATING CAPACITY	3 + 1 child
FUEL	PETROL
FUEL CAPACITY	28L
MAX. SPEED	40mph ≅ 64kph
No. TUBE COMPARTMENTS	4
CE DESIGN CATEGORY	C

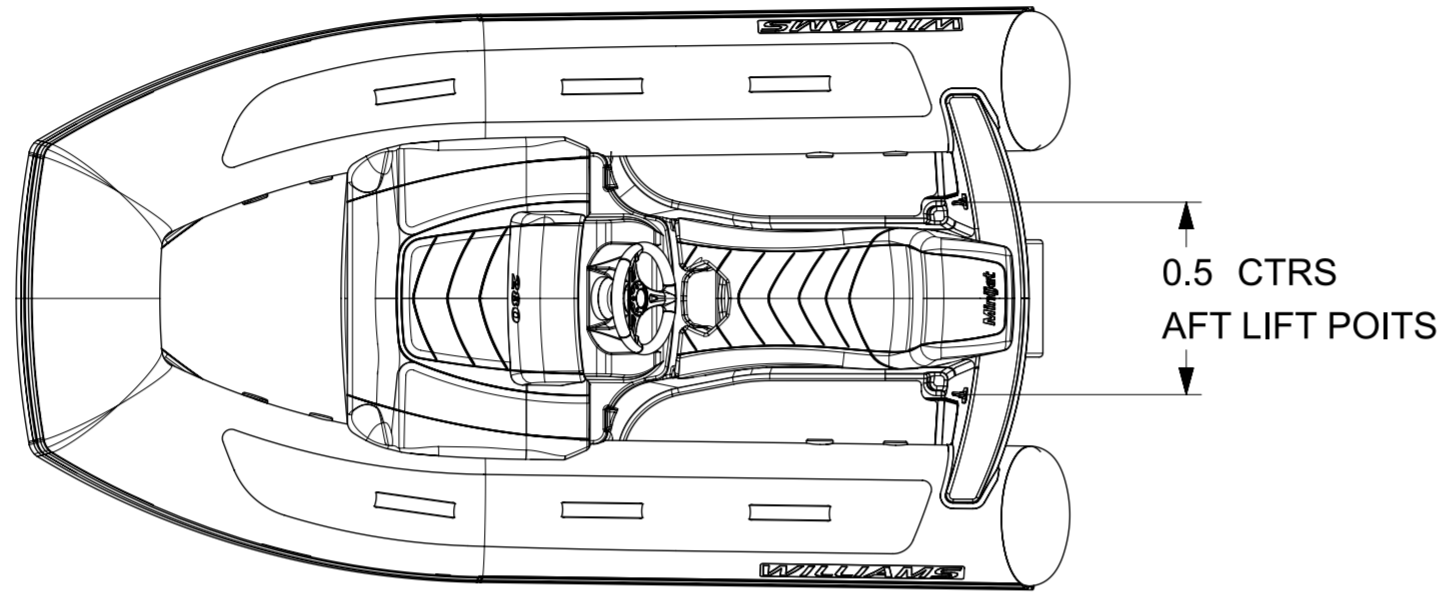

NOTES:

1. LENGTH / BEAM TOLERANCE DUE TO VARIATION IN TUBE PRESSURE.
2. AVERAGE DRY WEIGHT STATED;
ACTUAL WEIGHT DEPENDENT ON OPTIONS FITTED.
3. LOW PROFILE SPEC:
 - REMOVE STEERING WHEEL (QUICK RELEASE TYPE REQUIRED*)
 - DEFLATE TUBES.
4. CHOCK PROFILE'S DRAWING: RD927
CHOCKS* PART NUMBER: 99-0926

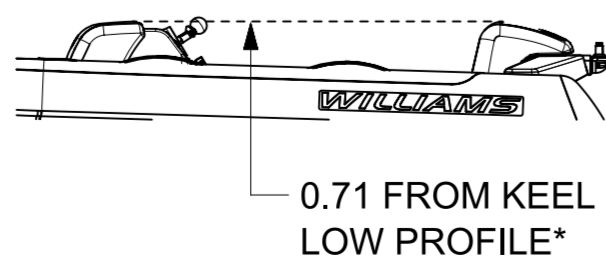
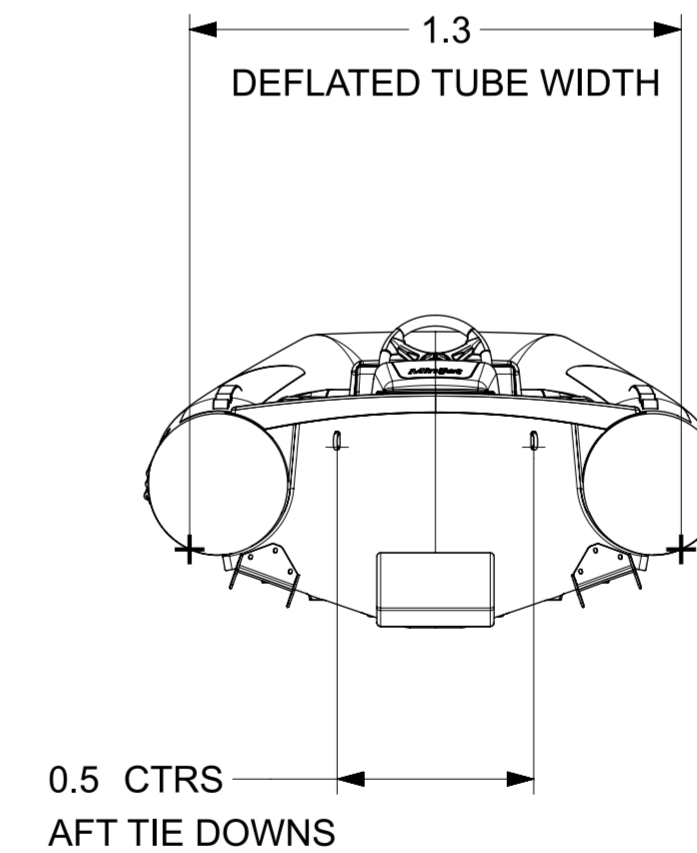
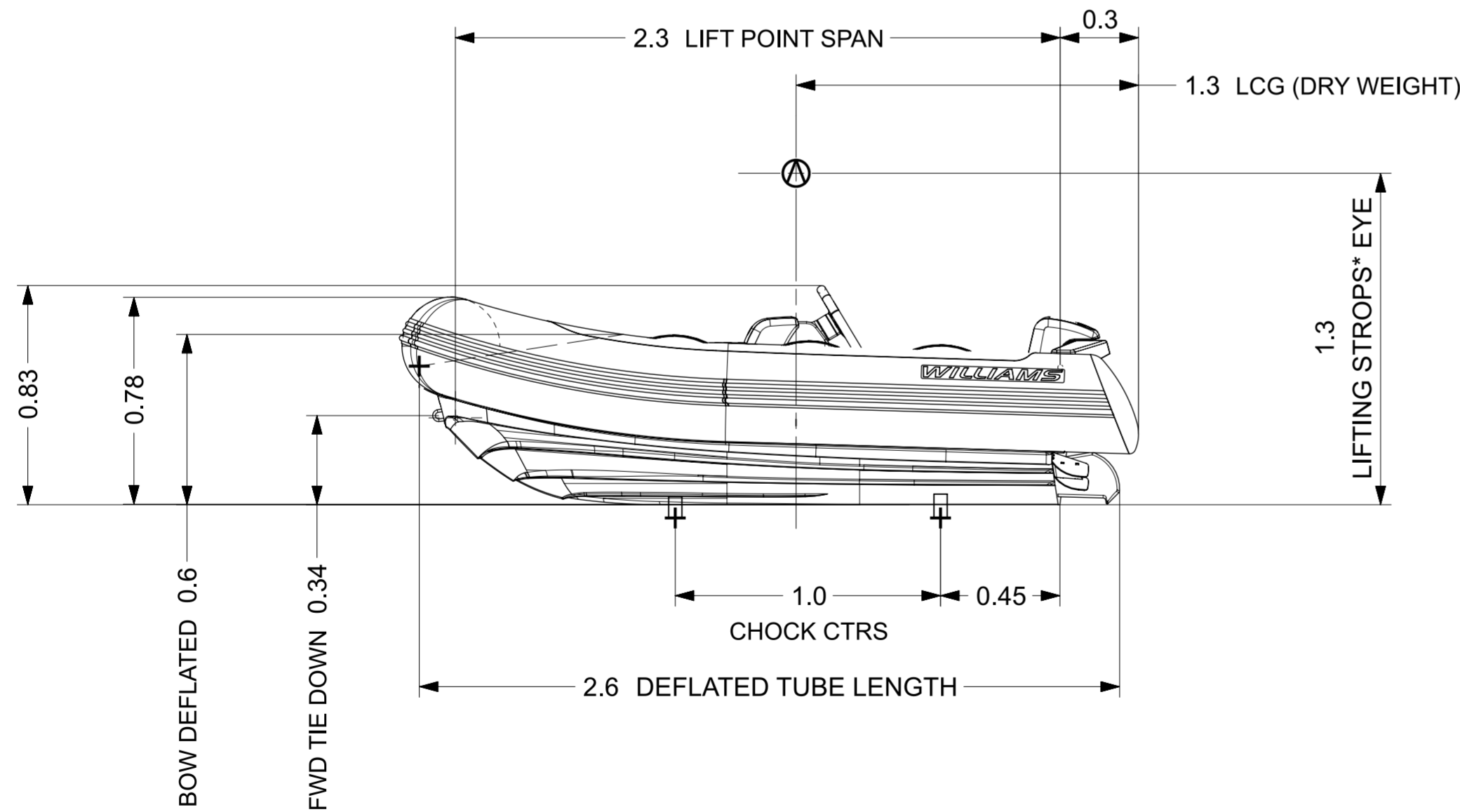

*OPTIONAL ACCESSORY

REV.	DATE	DETAILS	FZ	OB
1	11/10/2023	PRODUCTION RELEASED	FZ	OB
			DRAWN	APPVD

GENERAL TOL.	0 ±0.50
	0.0 ±0.25
	0.00 ±0.10
	0 ±0.30

DRAWN	FZ	11/10/2023
APPVD	OB	
PROJECT:	-	
INSPECTION LEVEL:	-	
MATERIAL & FINISH	-	
GENERAL SURFACE FINISH	Ra 1.6UM	
DIMENSIONS IN MM UNLESS STATED		
DO NOT SCALE DRAWING		

WILLIAMS	
TITLE	
MINIJET 280 (2024MY)	
PART NO.	WPT-000280MJ-2024MY-DATASHEET -dwg.1
SCALE	1:20
SHEET	1 OF 1

E